

# PRODUCT RANGE



**ITW Workholding**

Workholding - Worldwide

**FORKARDT**

AN ITW WORKHOLDING COMPANY

## T H E W O R L D W I D E

*FORKARDT is one of the most experienced manufacturers of workholding devices worldwide. Workholding developments and innovations from FORKARDT have been setting standards in the industry for decades - from the pioneering F type manual chucks, through indexing chucks right up to recent developments such as the highly innovative range of QLC power operated chucks.*

The acquisition of the FORKARDT group by Illinois Tool Works has created a cooperation that provides optimum workholding solutions worldwide as well as the necessary services to keep production processes of our customers trouble-free.

This truly international cooperation consists of the ITW Workholding group (USA) and Soul Teikoku Chuck (Japan) beside the European FORKARDT subsidiaries.

## WORKHOLDING SOLUTIONS WORLDWIDE



# D E S P E C I A L I S T



In addition to one of the most modern CAD network links worldwide, all companies within the Group have their own design and production departments. The highest standard of quality is assured, certified to DIN EN ISO 9001:2000.

Demanding users invest with FORKARDT not only in a high-precision standard or special chucks, but most deliberately in the quality and future success of their business. FORKARDT intends to remain the leading partner to the machine tool and engineering industries with its innovative concepts and solutions to both simple and complex problems.

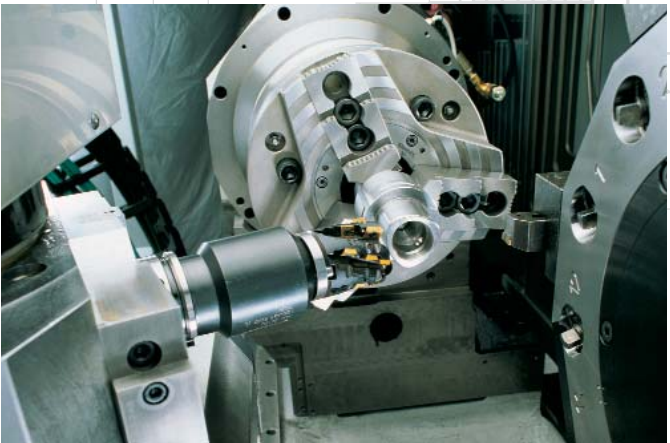
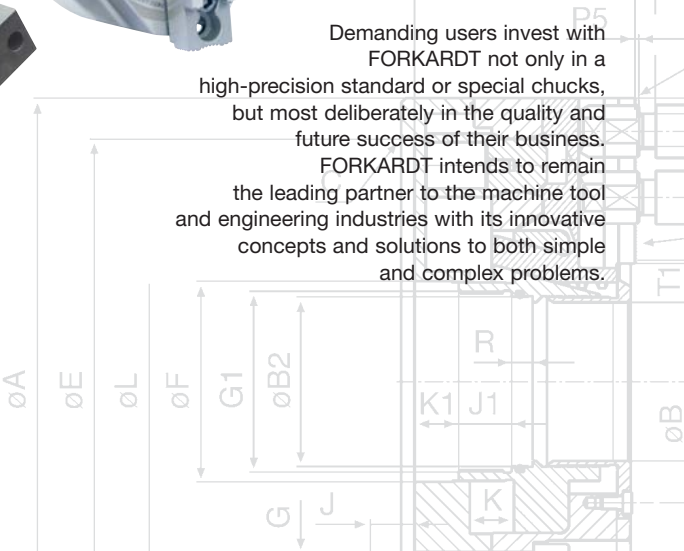



# Power chucks

## QLC/K



### • Applications

- Innovative (patented) universal chuck for all turning operations
- Suitable for heavy-cutting and fine finishing
- Large bore (-KS) and high speed variants

### Features

- Low-maintenance, high performance
- Forced circulation lubrication (patented)
- Multiple shaped jaw (patented)
- Backlash-free edge hook mechanism
- Centrifugal force compensation (QLK optional)
- Nitrided chuck body
- Speeds up to 8000 rpm

## QLC/K-KS



### • Features

- Larger through hole bore for handling larger diameter work pieces (77 - 168 mm)
- Extremely good proportion between through hole and outer diameter
- 40% greater through hole than comparable chucks

## 2/3 QLC-LS



### • Features

- 95 % more clamping stroke for work pieces with variations in diameter
- Easily grip stepped work pieces
- Available as 2- and 3-jaw QLC versions (QLK variants not available)

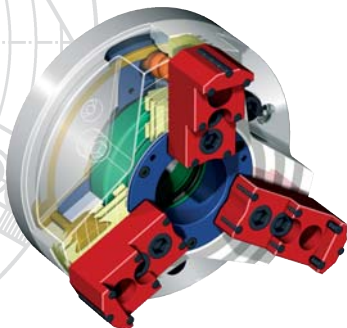

...the new series of QLC/K

More information at [www.itworkholding.com](http://www.itworkholding.com)



## QLC-AG

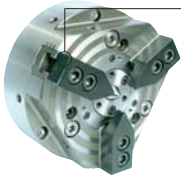

### Features

- Compensating chuck to clamp off-center parts with high precision
- Easy moving compensation even at high clamping forces
- Ingenious pull-back action for improved part location on center
- Easily interchangeable and finely adjustable center housings
- Simple change-over for self-centering mode for general chucking work

## QLC-KT



### Features

- Maximum gripping force
- Maximum speed
- Quick jaw change (simple automatization possible)

To meet these demands a full version has been developed from the reliable QLC chuck.

By combining the patented QLC guide ways with the robustness of elements of the KT chuck, a chuck characteristics has been reached which is optimal for heavy duty machining.

**PATENTED**

## V-Change



### Quick change Jaw system VC

#### Features

- Top jaws to be used for O. D. and I. D. clamping
- Jaw change system easily to be realised automatically (patented)
- Best repeatability (0,02) even under high clamping pressures
- Jaw change within approx. 5 seconds (ordinary systems 5-10 minutes)
- Highly efficient
- No additional base jaw necessary

...the new series of QLC/K

More information at [www.forkardt.com](http://www.forkardt.com)



# Power chucks

## FNC



### Applications

- Medium and small batch production

### Features

- Through hole bore
- Jaw quick-change system
- Identical jaws to F-Plus manual chucks

## 2, 3, 4 KT



### Applications

- Turning disk-shaped parts
- Precision finish machining

### Features

- Without through hole
- Heavy duty design for heavy cutting
- Variants also with two or four jaws
- Versatile for difficult work piece shapes

## LS



### Applications

- Production of mass-produced parts

### Features

- Virtually maintenance-free
- Hermetically sealed
- With lubricant filling
- For optional centric or compensating chucking
- Axial pull-back against fixed stock

## UBL



### Features

- Positive pull back action throughout gripping range
- Easy conversion from external to internal chucking
- Internally lubricated and sealed against contamination
- Offered in three different styles: Centralizing, compensating and "On-Off" - function to switch
- Integrated pendulum compensation for low deformation clamping

**ITW**  
Workholding

# Clamping cylinders



## OMHJ

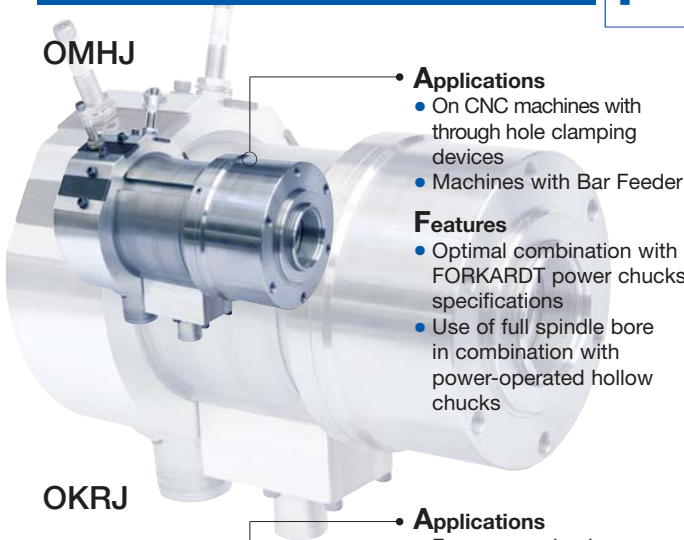

### Applications

- On CNC machines with through hole clamping devices
- Machines with Bar Feeder

### Features

- Optimal combination with FORKARDT power chucks specifications
- Use of full spindle bore in combination with power-operated hollow chucks

## OKRJ



### Applications

- For use on chucks without through hole bores
- Versatile design also allows use with through hole chucks

### Features

- Modular design
- Insertion of long work pieces possible
- Optional dynamic pressure monitor and cooling-water connection

## PZRJ

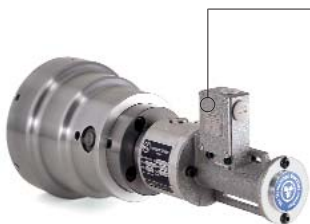

### Applications

- Without through bore for power-operated chucks, but can be used on chucks with and without centre hole

### Features

- Pneumatically operated
- Modular design
- Insertion of long work pieces possible
- Optional dynamic pressure monitor



# Manual chucks

F+



## Applications

- Universal wedge block chuck for conventional and CNC machines
- Quick-change jaw system standard for small lot sizes

## Features

- High gripping power
- Maximum precision
- Quick jaw change
- Large bore
- Easy to use
- Used successfully worldwide
- Nitrided chuck body

ATSC



## Applications

- Universal scroll chuck for conventional machines
- Suitable for diverse chucking tasks in small-series production

## Features

- 2-, 3-, 4- and 6-jaw types
- DIN and USA types
- Case-hardened steel chuck body
- Patented adjusting device *Ajust-Tru*®
- High-precision machine spindle alignment
- Good repetitive accuracy

PSA



## Applications

- For circular and irregular shaped parts
- Suitable for large machining tasks

## Features

- 4 independently adjustable jaws
- Long useful life
- Case-hardened steel body
- Quick-change jaws
- Easy resetting from inside to outside chucking



# Gripping jaws



## FGB/HB



- **Hard top jaws FGB and HB**
  - Hardened top jaw for universal application
  - Jaws can be ground in the chuck when mounted
  - Higher clamping force due to diamond style serration
  - Ready ground when delivered with a FORKARDT chuck

## FSTB



- **One piece stepped hard jaw FStB**
  - Hardened, one piece stepped jaws for universal application
  - Jaws can be ground in the chuck when mounted
  - Higher clamping force due to diamond style serration
  - Ready ground when delivered with a FORKARDT chuck
  - Optimum stability

## FGB/WBS

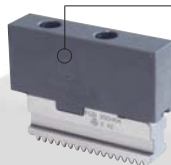

- **Soft top jaws FGB, WBL, WBS**
  - Ideal for clamping on machined surfaces
  - High precision due to grinding of jaws under clamping pressure in the chuck
  - Jaws are available in different dimensions

## FMB



- **One piece stepped soft monoblock jaw FMB**
  - Ideal for clamping on machined surfaces
  - High precision due to grinding of jaws under clamping pressure in the chuck
  - Maximum chucking length
  - Optimum stability



# Gripping jaws

## NSTK



### Jaw holder system NSTK T-sliding block

- Standardised soft top jaws – for individual applications
- Claw jaws for internal and external chucking with SKA and SKI clamping inserts
- A more variable and wider clamping range is offered by the added option of shifting the chuck jaw and T-sliding block.
- Free arrangement without restrictions through holes compared to conventional WBL system with screw fixing.
- Rapid jaw shifting and changing.
- Suitable for use on all Forkardt chucks with serrated jaws in inches.
- Chuck sizes from 160 mm to 630 mm diameter.
- Simplified jaw changing on pick-up machines.

## KBNKLA



## KBNKLI



## KBKTNC



### Roughing jaw-system KBKTNC

- Maximum cutting performance at highest gripping forces
- Less time for cutting operation needed at given clamping force
- Highly efficient due to changeable claw inserts

## VC



### Soft Top Jaws VC - External and Internal O.D. clamping

I.D. clamping

### Automatic Jaw Change

In order to change jaws automatically in the VC-system one needs simple devices for O. D. and I. D. clamping. These devices are appointed on conception of the clamping task.



## Features

- Accuracy of 0.002 mm
- Hermetically sealed
- Permanent lubrication
- Virtually maintenance-free
- Easy to use

## Cylindrical grinding

KCHP



### • Three-jaw power-operated chuck

- Diameters: 130 – 400 mm
- Suitable for use on cylindrical grinding machines
- Available with integrated cylinder or as solid front-end chuck with cylinder and air feed ring
- For floating work piece driving
- Ideal for automated production



### • Power-operated chucks for gears, cam and crankshafts

- Easy resetting to gear machining with quick jaw change
- Exact chucking in pitch circle
- Chucking of various modules or tooth numbers by changing the clamping pinion
- Machining of unstable work pieces between centres
- Torques up to 150Nm without affecting the work piece geometry
- TIR up to 0.0025 mm





KCHS

## Precision-turning and hard-turning

- **Centric and eccentric chucking**
  - Fixed eccentric dimension
  - Manually adjustable eccentric dimension
  - Automatically adjustable



## Diaphragm Chucks



**ITW**  
Workholding

- **Sheffer style diaphragm chucks**
- **Traditional N. A. Woodworth chucks**

### Features

- Low maintenance
- Positive pull back against stop
- 0.0025 mm repeatability
- 3 - 6 jaw models available
- Quick change options available
- For gear chucking solid jaws, universal jaws or cage styles are available
- Jaw designs as Dovetail, master jaw or integral designs

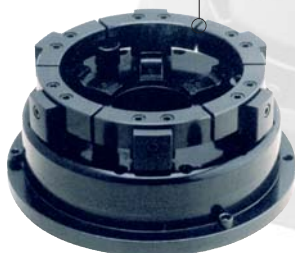

**ITW**  
Workholding



## 3LDH



### • 3LDH

- Speeds up to 11,000 rpm
- Maintenance-free permanent lubrication
- Integrated centrifugal force compensation system
- High stability due to hermetic sealing
- Precise vibration-free TIR



### • Crank and camshaft chucks

- Maximum reliability with minimum maintenance
- Fast resetting to other work piece types
- Easy adjustment of chuck body to turning centre
- Repetitive accuracy < 0.03 mm
- Optimal chip clearance due to smooth chuck contours

## HSFJ



## HSR



## ZS



### • Indexing chucks HSFJ, HSR, ZS

- Modern indexing chuck range with all the features of advanced chuck design
- Hydraulically controlled functions can also be fed back electromechanically
- Hydraulic centrifugal balancing permitting maximum speeds
- Main and intermediate settings can be selected program-controlled
- Conception and design in close cooperation with users
- Extremely strong and accurate position lock allows heavy cuts with short tools



# Expanding mandrels

## EM



### • Precision draw-in arbors

- Clamping range between 12.5 and 350 mm
- Hand and power-operated precision draw-in arbors
- Easy to use, proven clamping device for internal chucking
- Double-cone clamping system with slotted sleeves
- Variable program for optimal clamping system development
- Ground according to customer requirements

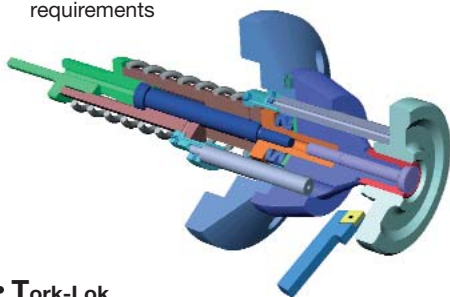

### • Tork-Lok

- The Woodworth Tork-Lok system consists of arbors and collets, in short or long style design
- In combination with lightweight air cylinder available as a complete self-contained system
- Special fixtures are available to answer many machining needs (e.g. milling, boring or gear cutting)
- Long and short series models are available in the between centers type
- Standardized products that are interchangeable and allow for combinations of components



**ITW**  
Workholding

## D + DH



### • Lamella-type draw-in arbors

- Hand and power-operated precision arbors
- The arbor lamellae move precisely radial to the clamping movement
- Chucking adapted to the total work piece length
- Ideal for automated work piece feeding
- Easy resetting from power to manual chucking



## • Lamella-type draw-in collet chuck

- Wide chucking ranges covered
- High chucking precision
- Differences between 4.5 and 15 mm can be accommodated
- Low lamella weight results in minimal gripping power losses at high speed

VEZ

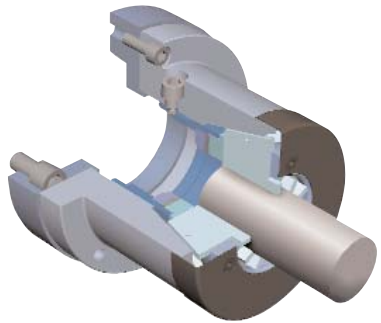

LZK

ZKSB



## • Power-operated draw-in collet chuck

- Front bayonet lock
- Featuring push-type collet chucks to DIN 6343 or Rubber-Flex collet chucks
- Fast collet chuck changing
- Easy to use
- Low cost interchangeable chuck, ideal for work pieces and bar stock sensitive to deformation



## Collet chucks

### 6 TGC 140



#### • Precision Tool Grind Chuck

##### Features

- Chuck O.D. 140
- Clamping range: 2 to 17 mm
- With stroke limitation
- Clamping repeatability: 0.005 mm
- Max. speed: 500 rpm
- Air purge with oil mix for minimum maintenance
- Clamping force Fsp 8000 Newton
- Clamping of workpart with no length movement (axial fix)

\*More data upon request

Highly precise blade arbor with clamping fingers, universally applicable

**EXCELLENT** for precise sharpening of cutting tools over wide clamping range – no idle time for toolholder change

**IDEAL** for precision tool grinding and hard turning operation, offering a rigid design, along with air purge with oil mix for lasting accuracy

**OPTIMAL** for any tool grinding operation requiring both wide gripping range and high accuracy



Highest  $\mu\text{m}$ -precision and quality!





SKM



## Gripping force measuring devices

SKM series devices are electronic/mechanical compact units using C-MOS technology. They are designed for the routine testing of chucks and ensure reliable production. Prescribed in the European standard EN 1550.

Available in hand held and desktop versions





## Steady rests

### TYP L



#### Features

- Indispensable for machining slender, shaft-like work pieces
- Permanently mounted on machine bed
- Self-centering
- With safety valve and optional block cylinder at rear or laterally
- Multiple or central lubrication
- With optional position monitoring and swing-out lever



# Shock absorbers

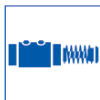

## SDC



### Industrial shock absorbers

All series SDC shock absorbers are:

- Self adjusting
- Universally applicable
- Cost effective and feature:
  - High energy absorption
  - High safety margins
  - High reliability
  - Prolonged service
  - Metric dimensions
- Product quality to traditionally high German standards

## SDKNE/SDKZE



### Crane shock absorbers

FORKARDT - crane shock absorbers offer many advantages, such as:

- Low definable deceleration loads
- Approximately constant deceleration power or linear deceleration
- Reduction of stopping load on failures of control or operation errors
- Protection of the accompanying operation personnel
- Reduction of the risk of accidents

## SDVN



### Industrial shock absorbers

Advantages at a glance:

- 46 various sizes
- According to requirements
- DIN / ISO
- Adjustable at both ends
- Depending on requirements four different seal systems available
- Mounting variations
- Strengthened piston rod
- Special versions

# WORKHOLDING SOLUTIONS WORLDWIDE



## LOCATIONS WORLDWIDE

**FORKARDT DEUTSCHLAND GMBH**  
 Heinrich-Hertz-Str. 7  
 D-40699 Erkrath  
 Tel: (+49) 211-25 06 0  
 Fax: (+49) 211-25 06 221  
 E-Mail:  
 info@forkardt.com

**FORKARDT SCHWEIZ GMBH**  
 Industriestrasse 3  
 CH-8307 Effretikon  
 Tel: (+41) 52-355 3131  
 Fax: (+41) 52-343 5240  
 E-Mail:  
 info-ch@forkardt.com

**FORKARDT FRANCE S.A.R.L.**  
 28 Avenue de Bobigny  
 F-93135 Noisy le Sec Cédex  
 Tel: (+33) 1-4183 1240  
 Fax: (+33) 1-4840 4759  
 E-Mail:  
 forkardt.france@forkardt.com

**BUCK CHUCK**  
 2155 Traversefield Drive  
 Traverse City, MI 49686, USA  
 Tel: (+1) 231-995 8312  
 Fax: (+1) 231-941 2466  
 E-Mail:  
 buck.forkardt@forkardt.com

**N.A. WOODWORTH**  
 2155 Traversefield Drive  
 Traverse City, MI 49686, USA  
 Toll Free: 800-544 3823  
 Fax: (+1) 248-743 4401  
 E-Mail:  
 sales@itworkholding.com

**FORKARDT NORTH AMERICA**  
 2155 Traversefield Drive  
 Traverse City, MI 49686, USA  
 Tel: 248-743-4400  
 800-794-6190  
 Fax: 248-743-4401  
 E-Mail: info@forkardtusa.com

[www.forkardt.com](http://www.forkardt.com)

[www.itworkholding.com](http://www.itworkholding.com)